

PRODUCT NUMBER  
SEE TABLE

Co. LOGO WILL APPEAR ON THIS SURFACE IF HOUSING HAS A MINIMUM OF 8 POSITIONS. Co. LOGO AND PART NUMBER WILL APPEAR ON THIS SURFACE IF HOUSING HAS A MINIMUM OF 16 POSITIONS.

CAVITIES WILL BE MARKED STARTING WITH THE FIRST POSITION AND CONTINUING EVERY FOURTH POSITION AS SHOWN. CHARACTERS ARE TO BE .06 HIGH. NO PRINTING WILL OCCUR ON A HOUSING WITH LESS THAN 8 POSITIONS.

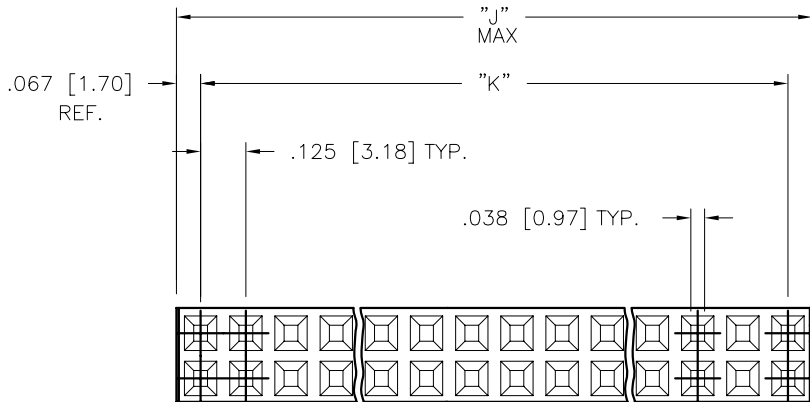
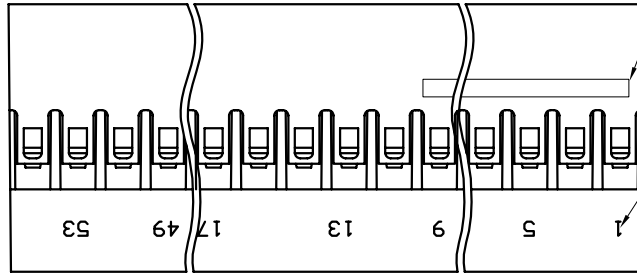

.044 [1.12] TYP.

.125 PIN CENTERS WITH MAXI P.V.<sup>TM</sup> TERMINALS INSTALLED.

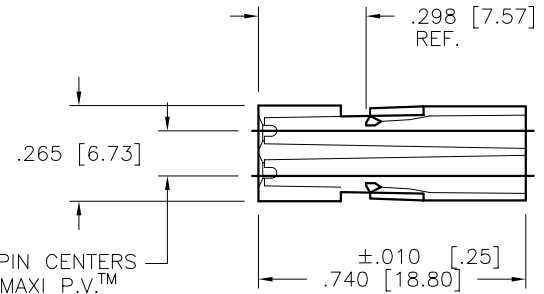

Copyright FCI

mat'l code SEE NOTE 1				surface	tolerance	projection	product family
				✓			PV HOUSINGS
ltr	ecn no	dr	date	tolerances unless otherwise specified		INCH/MM	title
G	v80287	LSS	1995-03-31	angles	linear		MAXI LATCH HOUSING DR
H	v60479	EPK	1995-04-04				.125 [3.18] X .125 [3.18] CC
J	v90981	RGD	1999-06-21	0° ± 2°		scale 2:1	
K	v03-1333	PJ	2004-01-14	dr	L. SANDERS	1995-03-31	dwg no
L	v05-0713	DAI	2005-07-29	engr	L. FYE	1995-03-31	sheet 1 of 3
M	v06-0454	HTB	2006-05-25	chr	T. BREWBAKER	1995-03-31	size
N	v07-0493	HTB	2007-07-27	appd	L. FYE	1995-03-31	A3
sheet	revision	N	N	N			type
index	sheet	1	2	3			Product Customer Drawing

PRODUCT NUMBER  
SEE TABLE

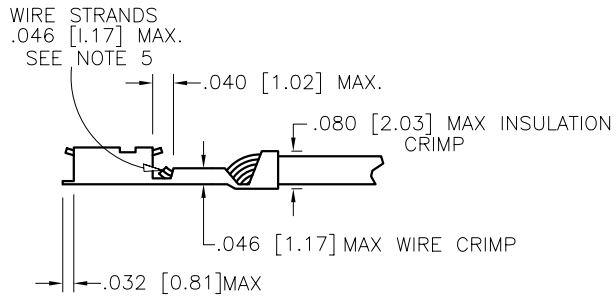

FIG 4

NOTES:

- ①. MOLDING MATERIAL: MODIFIED POLYPHENYLENE ETHER, FLAME RETARDANT PER UL-94V-0, COLOR: BLACK.
2. PIN LENGTH TO BE .250 [6.35] MIN. RECOMMENDED PIN LENGTH IS .265±.015 [6.720 ±.380]
- ③. TO LATCH TERMINAL—PUSH AS SHOWN IN FIGURE #1, BE SURE THAT LATCH SNAPS DOWN. MINIMUM PULL-OUT FORCE OF TERMINAL WILL BE 6.5 LBS[2.9Kg]. (WHEN PULLED AS SHOWN).
- ④. TO REMOVE TERMINAL—PUSH TERMINAL FORWARD. LIFT LATCH WITH HANDTOOL. AS SHOWN IN FIG. #2 & 3. DAMAGE TO LATCH CAN OCCUR IF LIFTED MORE THAN 25° ANGLE TO TOP OF HOUSING.
- ⑤. MAX. WIRE CRIMP AND WIRE STRANDS ARE SHOWN IN FIGURE #4. IF THIS IS EXCEEDED, LATCHING WILL NOT BE SATISFACTORY SEE MAXI PV™ TERMINAL SPECIFICATION TA-213 FOR CORRECT CRIMP HEIGHT FOR EACH DIFFERENT WIRE SIZE.
6. THIS HOUSING IS INTENDED FOR USE MAXI PV™ TERMINAL WITH 18-32 GAGE WIRE MEETING SPECIFICATION SHOWN IN FIGURE # 4.
7. PRODUCT MEETS EUROPEAN UNION DIRECTIVES AND OTHER COUNTRY REGULATIONS AS DESCRIBED IN GS-22-008.
8. THIS PRODUCT IS NOT INTENDED TO BE EXPOSED TO MANUFACTURING SOLDER PROCESSES.

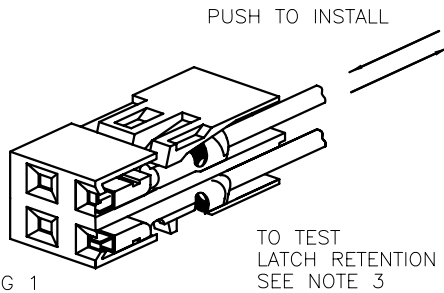

FIG 1

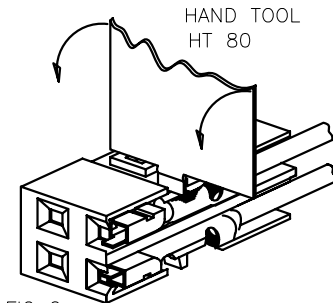

FIG 2

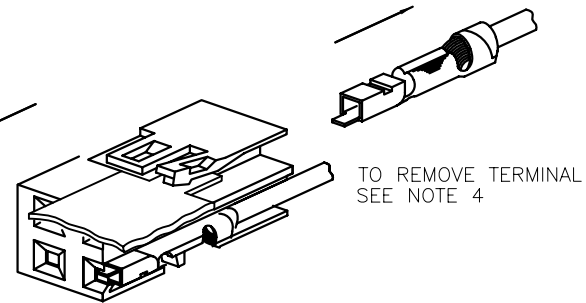

FIG 3

mat'l. code SEE NOTE 1				surface	tolerance	projection	product family PV HOUSINGS		
ltr	ecn no	dr	date	tolerances unless otherwise specified			INCH/MM	title	
N				angles	linear	scale 2:1		MAXI LATCH HOUSING DR	
				0°±2°	.XX+01/XX-3 XXX+005/XX+13 XXXX+0020/XXX+051			.125 [3.18] X .125 [3.18]CC	
				dr	L. SANDERS	1995-03-31	FCJ	dwg no	sheet 2 of 3
				engr	L. FYE	1995-03-31		65410	A3
				chr	T. BREWBAKER	1995-03-31		type Product Customer Drawing	
				appd	L. FYE	1995-03-31			
sheet	revision								
index	sheet								

PRODUCT NUMBER	NO OF POS	DIM J MAX	DIM K	STAMPING NOTES
65410-004LF	2 X 2	.267/6.78	.125/3.18	DON'T STAMP
65410-006LF	2 X 3	.392/9.96	.250/6.35	DON'T STAMP
65410-008LF	2 X 4	.517/13.13	.375/9.53	LOGO
65410-010LF	2 X 5	.642/16.31	.500/12.70	LOGO
65410-012LF	2 X 6	.767/19.48	.625/15.88	LOGO
65410-014LF	2 X 7	.892/22.68	.750/19.65	LOGO
65410-016LF	2 X 8	1.017/25.83	.875/22.23	LOGO & PART NO.
65410-018LF	2 X 9	1.142/29.01	1.000/25.40	LOGO & PART NO.
65410-020LF	2 X 10	1.267/32.18	1.125/28.58	LOGO & PART NO.
65410-022LF	2 X 11	1.392/35.36	1.250/31.75	LOGO & PART NO.
65410-024LF	2 X 12	1.517/38.53	1.375/34.93	LOGO & PART NO.
65410-026LF	2 X 13	1.642/41.71	1.500/38.10	LOGO & PART NO.
65410-028LF	2 X 14	1.767/44.88	1.625/41.38	LOGO & PART NO.
65410-030LF	2 X 15	1.892/48.07	1.750/45.05	LOGO & PART NO.
65410-032LF	2 X 16	2.017/51.23	1.875/47.63	LOGO & PART NO.
65410-034LF	2 X 17	2.142/54.41	2.000/50.80	LOGO & PART NO.
65410-036LF	2 X 18	2.267/57.58	2.125/53.98	LOGO & PART NO.
65410-038LF	2 X 19	2.392/60.76	2.250/57.15	LOGO & PART NO.
65410-040LF	2 X 20	2.517/63.93	2.375/60.33	LOGO & PART NO.
65410-042LF	2 X 21	2.642/67.11	2.500/63.50	LOGO & PART NO.
65410-044LF	2 X 22	2.767/70.28	2.625/66.68	LOGO & PART NO.
65410-046LF	2 X 23	2.892/73.46	2.750/69.85	LOGO & PART NO.
65410-048LF	2 X 24	3.017/76.63	2.875/73.03	LOGO & PART NO.
65410-050LF	2 X 25	3.143/79.81	3.000/76.20	LOGO & PART NO.
65410-052LF	2 X 26	3.267/82.98	3.125/79.38	LOGO & PART NO.
65410-054LF	2 X 27	3.392/86.16	3.250/82.55	LOGO & PART NO.
65410-056LF	2 X 28	3.517/89.33	3.375/85.73	LOGO & PART NO.
65410-057LF	DISCONTINUED			

mat'l. code SEE NOTE 1		surface <input checked="" type="checkbox"/>	tolerance	projection	product family PV HOUSINGS
ltr	ecn no	dr	date	tolerances unless otherwise specified	title
N				linear	INCH/MM
				0"±2"	scale 1:1
		dr	L. SANDERS	1995-03-31	
		engr	L. FYE	1995-03-31	
		chr	T. BREWBAKER	1995-03-31	
		appd	L. FYE	1995-03-31	
sheet	revision				dwg no
index	sheet				65410
					sheet 3 of 3
					size A3
					type Product Customer Drawing



Copyright FCJ